

Swing cylinders - Upper flange models

Shown: SURS-202, SURS-52



SU series

The Enerpac upper flange swing cylinders are designed for integrated manifold mounting solutions. Hydraulic connections are made through SAE or BSPP oil connection or the standard integrated O-ring ports.

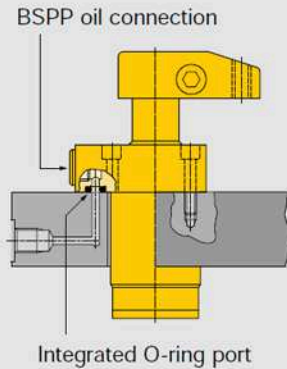

■ Enerpac upper flange swing clamps integrated into a fully automated machining system.



Minimal mounting height

...when space is at a premium

- Flexible design allows for manifold or threaded port connection
- Low profile mounting style allows body to be below mounting surface
- Simple mounting preparation and easy installation – 3 or 4 mounting bolts
- Easy to machine fixture hole – does not require tight tolerances
- Double oil connection – threaded port or manifold mount
- Symmetrical rectangular flange design enables clamping at three sides of the cylinder

Product selection

Clamping force ¹⁾	Stroke		Left turning 90°	Right turning 90°	Cylinder effective area		Oil capacity		Max. oil flow ¹⁾	Standard clamp arm Sold separately □ 24 ▶
	kN	Clamp.			Total	cm ²	Un-clamp	cm ³		
▼ Single-acting										
Model number ²⁾										
2,1	8,1	16,5	SULS-22	SURS-22	0,77	-	1,31	-	0,2	CAS-22
4,9	9,9	22,6	SULS-52	SURS-52	1,81	-	4,10	-	0,4	CAS-52
8,0	11,9	22,1	SULS-92	SURS-92	3,16	-	6,88	-	1,0	CAS-92
10,7	12,7	28,4	SULS-121	SURS-121	4,06	-	11,47	-	1,6	CAS-121
17,4	14,0	27,9	SULS-202	SURS-202	7,10	-	19,99	-	2,3	CAS-202
33,1	16,0	30,0	SULS-352	SURS-352	12,39	-	37,20	-	3,9	CAS-352
▼ Double-acting										
Model number ²⁾										
2,2	8,1	16,5	SULD-22	SURD-22	0,77	1,55	1,31	2,62	0,2	CAS-22
5,6	9,9	22,6	SULD-52	SURD-52	1,81	3,81	4,10	8,69	0,4	CAS-52
9,0	11,9	22,1	SULD-92	SURD-92	3,16	8,06	6,88	17,70	1,0	CAS-92
9,0	32,0	41,9	SULD-92	SURDL-92	3,16	8,06	13,27	30,48	1,0	CAS-92
11,6	12,7	28,4	SULD-121	SURD-121	4,06	7,94	11,47	22,94	1,6	CAS-121
11,6	31,8	47,5	SULD-121	SURDL-121	4,06	7,94	15,90	37,69	1,6	CAS-121
18,7	14,0	27,9	SULD-202	SURD-202	7,10	15,16	19,99	42,61	2,3	CAS-202
33,8	16,0	30,0	SULD-352	SURD-352	12,39	23,74	37,20	71,28	3,9	CAS-352
33,8	31,8	46,5	SULD-352	SURDL-352	12,39	23,74	57,85	110,94	3,9	CAS-352

¹⁾ With standard clamp arm. Clamp arms are sold separately (□ 10, 24). Clamping forces for single-acting models are reduced in order to overcome return spring force.

Note: Call Enerpac to order models with SAE port connections.

²⁾ For models with straight plunger movement, replace L or R with S.

Dimensions in mm [D]

Left turning models	A	B	C	D	D1	D2	F	H	K	M	N	P
▼ Single-acting												
SULS-22	112,0	59	42,5	27,9	47,2	45	10	11	16	-	15,5	24
SULS-52	134,9	69	49,6	34,8	54,1	57	16	10	19	-	19,1	40
SULS-92	143,0	75	50,1	47,8	70,1	54	25	13	25	15,5	26,9	45
SULS-121	171,5	86	55,4	47,8	66,8	73	22	10	30	-	25,4	51
SULS-202	165,1	86	55,9	63,0	85,1	70	32	13	30	23,6	35,1	55
SULS-352	186,4	98	58,0	77,0	100,1	89	38	13	40	27,9	44,5	68
▼ Double-acting												
SULD-22	112,0	59	42,5	27,9	47,2	45	10	11	16	-	15,5	24
SULD-52	134,9	69	49,6	34,8	54,1	57	16	10	19	-	19,1	40
SULD-92	143,0	75	50,1	47,8	70,1	54	25	13	25	-	26,9	45
SULD-92	182,9	95	69,9	47,8	70,1	54	25	13	25	-	26,9	45
SULD-121	171,5	86	55,4	47,8	66,8	73	22	10	30	-	25,4	51
SULD-121	228,6	105	74,5	47,8	66,5	73	22	10	30	-	25,4	51
SULD-202	165,1	86	55,9	63,0	85,1	70	32	13	30	-	35,1	55
SULD-352	186,4	98	58,0	77,0	100,1	89	38	13	40	-	44,5	68
SULD-352	217,9	114	74,5	77,0	100,1	89	38	13	40	-	44,5	68

Note: Dimensions shown with standard clamp arm.

We offer a Full Range of Hydraulic Products from a comprehensive range of manufacturers to bring you the products and systems most suited to your applications



Dimensions & options SU series



Installation dimensions in mm

Clamping force ¹⁾ kN	Fixture hole Ø D3 ±0,3	Mounting thread J	Min. depth J2	Manifold O-ring ²⁾ ARP nr. or Inside Ø x thickness
2,2	29,0	M5	16,5	568-010
5,6	35,5	M6	16,5	568-011
9,0	49,0	M6	15,0	4,32 x 3,53
11,6	49,0	.312-24 UN	20,3	568-011
18,7	63,5	M8	17,0	4,32 x 3,53
33,8	78,0	M10	18,8	4,32 x 3,53

¹⁾ With standard clamp arm.
²⁾ Polyurethane, 92 Durometer

Note: Mounting bolts and O-rings included.

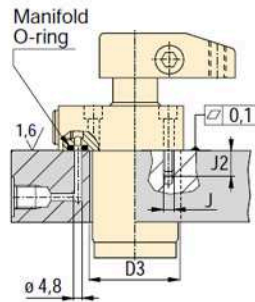

Force:	2,1 - 33,8 kN
Stroke:	16,5 - 47,5 mm
Pressure:	35 - 350 bar

- (E) Cilindros giratorios
- (F) Verins de bridage pivotants
- (D) Schwenkspannzylinder

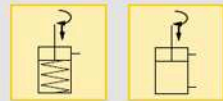

-22, 52, 121

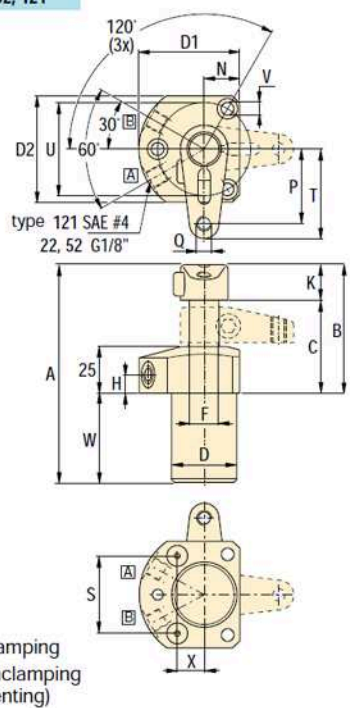

[A] = Clamping
[B] = Unclamping (venting)

-92, 202, 352

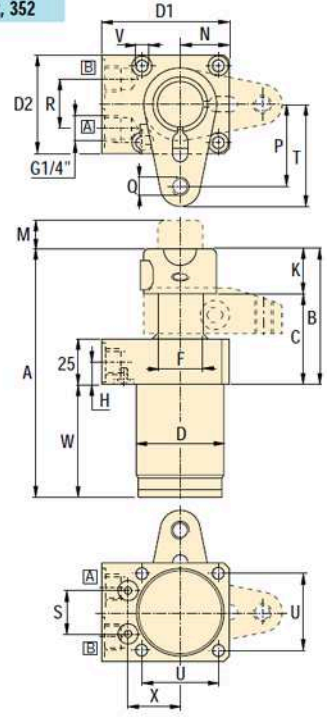

Options

- Clamp arms □24 ▶
- Work supports □28 ▶
- Collet-Lok® swing cylinders □22 ▶
- Sequence Valves □92 ▶

Important

Single-acting cylinders can be vented through the manifold port.

The upper flange swing cylinder has a bolt pattern which is identical to its lower flange equivalent, enabling interchangeability.

In case there is a risk of machining coolants and debris being inhaled via the breather vent, it is recommended to pipe this port to an area outside the fixture that is protected from machining coolants and debris.

Do not exceed maximum flow rates.

	Q	R	S	T	U	V	W	X	kg	Right turning models
						α				
										Single-acting ▼
	M6x1	-	21,0	30	40	5,7	53,1	18,1	0,5	SURS-22
	M8x1,25	-	41,0	48	50	6,8	66,0	14,3	1,1	SURS-52
	M10x1,5	26	23,6	56	42	6,9	68,1	28,7	2,0	SURS-92
	.375-16UN	-	52,4	61	64	8,8	85,9	18,4	1,6	SURS-121
	M12x1,75	26	29,2	71	55	8,5	79,0	35,6	3,5	SURS-202
	M16x2	25	34,4	84	70	10,8	88,4	41,6	5,5	SURS-352
										Double-acting ▼
	M6x1	-	21,0	30	40	5,7	53,1	18,1	0,5	SURD-22
	M8x1,25	-	41,0	48	50	6,8	66,0	14,3	1,1	SURD-52
	M10x1,5	26	23,6	56	42	6,9	68,1	28,7	2,0	SURD-92
	M10x1,5	26	23,6	56	42	6,9	87,9	28,7	2,6	SURDL-92
	.375-16UN	-	52,4	61	64	8,8	85,9	18,4	1,6	SURD-121
	.375-16UN	-	52,4	61	64	8,8	124,0	18,4	1,8	SURDL-121
	M12x1,75	26	29,2	71	55	8,5	79,0	35,6	3,5	SURD-202
	M16x2	25	34,4	84	70	10,8	88,4	41,6	5,5	SURD-352
	M16x2	25	34,4	84	70	10,8	104,3	41,6	6,8	SURDL-352

Note: U = Bolt circle, U1 = Manifold port circle.

We offer a Full Range of Hydraulic Products from a comprehensive range of manufacturers to bring you the products and systems most suited to your applications

